

ERA-PRXPG Motion Kit

Owner's Manual

Introduction

The ERA-PRXPG is a doorbell/entry alert kit that features the ERA-PIR motion sensor, the ERA-DCRX and a strobe light.

The ERA-PIR is a passive infrared (PIR) sensor/transmitter compatible with the ERA-RXPG Receiver. The ERA-PIR is activated when a combination of heat & movement is detected in the monitored zone. When the transmitter is activated, it will send a signal to the receiver which will sound one (1) of twelve (12) different melodies or tones for a few seconds.

Helpful Tips:

- Do not mount the transmitter (ERA-PIR) to the wall or door frame until you have successfully paired & tested the device.
- Each receiver (ERA-RXPG) is capable of pairing with twelve (12) transmitters.
- There is virtually no limit to the number of receivers (ERA-RXPG) a transmitter may be paired to.
- There are three modes of operation for the ERA-RXPG; sound only, strobe only, sound and strobe.
- Volume control: 4 levels plus mute, plus off.
- All ERA transmitters/sensors are cross-compatible with all ERA receivers.
- To expand the kit, add more receivers such as the ERA-RXPG, ERA-DCRX, and the ERA-VPRX.
- Add more sensor/transmitters to this kit such as the ERA-PBTX push button, ERA-PIR motions sensor, ERA-DSTX driveway sensor, and the ERA-UTX magnetic door contact.

ERA-PIR Battery Installation:

The sensor is powered by a 9V alkaline battery. Follow the steps below to remove the cover and install the battery. **Note:** Program the tone and volume level prior to reassembling the unit.

1. Remove the screw located on the backside of the case using a phillips head screwdriver (see figure 1). Once the screw is removed, open the case.
2. Remove top half of case from lower half of the case to find the battery holder (see figure 2).
3. Install a fresh 9-volt alkaline battery.
4. Follow the instructions for **"Programming the Sensor/Transmitter to a Receiver"**.

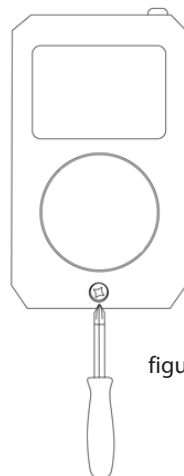
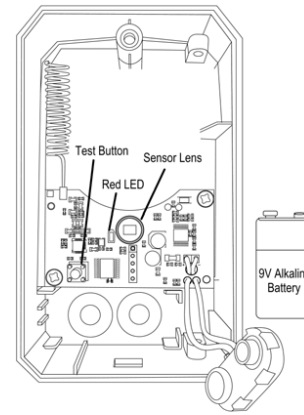

figure 1.



Programming the Sensor/Transmitter to a Receiver:

(Always test unit prior to final installation)

The transmitter works with all ERA receivers. Basic programming calls for the user to program a transmitter to the receiver & select a melody for the receiver to play when triggered by the transmitter. In the example below, the transmitter will be programmed to the ERA-RXPG plugin receiver. If you are using a different ERA receiver, follow the programming instructions for that receiver to put the receiver in programming mode & to change the melody.

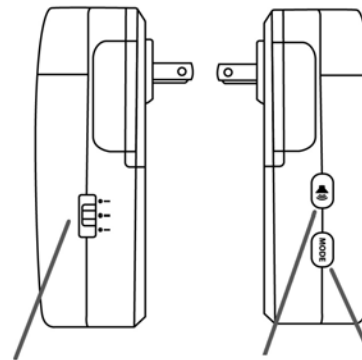

ERA-PIR Transmitter

figure 3.

Operation Mode Selector Switch	Melody Selector/ Volume Control	Programming Button
--------------------------------	---------------------------------	--------------------

1. Ensure the ERA-RXPG is plugged into a standard wall outlet.
2. On the ERA-RXPG receiver, hold down the "mode" button (lower button in figure 2) until you hear a short tone sound & the red LED (inside the front lens cover) begins to blink. This denotes the unit is in programming mode. Release this button.
3. Scroll through available melodies by pressing the melody selector button. Stop pushing this button when you hear the sound you want the respective push button to play.
4. Push the center push on the push button. The receiver will play a quick chime sound notifying the transmitter is programmed to the receiver. The red LED should still be blinking.
5. If you want to program a second transmitter (push button, door contact, motion sensor, or driveway sensor) push the melody selector button (the button on top) to scroll through available melodies. Once you have the sound you want, stop pressing the melody selector button and repeat step 4 above, triggering the sensor/transmitter.
6. Once you have programmed all the transmitter(s), exit programming mode by holding down the "mode" button until you hear a short tone sound & the red LED disappears (approx 3 seconds).

Test the Programming of Transmitter to Receiver:

- Ensure the ERA-RXPG receiver is plugged in & the battery is installed in the ERA-PBTX push button.
- Push the center button of the ERA-PBTX push button.
- When pressed, the green halo around the center push should brightly illuminate.
- When triggered the receiver should play the selected melody and/or flash. Make sure the receiver is set to sound mode by moving the selector switch on the side of the receiver to sound only or sound + strobe (middle or lower position of selector switch).

Changing the Zone Melody:

By default, each zone is programmed by the factory to play the ding-dong sound. You can skip this step if you are ok with that sound.

1. Hold down the "zone" button until you hear a short tone & all LEDs on front panel of receiver are red (approx 3 seconds). The zone you are programming will flash (see figure 2).
2. Press the "volume" button to scroll through the 12 available melodies for selection. Once you find a melody you like, move to step 3. Press the "zone" button to scroll to the next zone & repeat step 2 to program a melody to other zones. Once you have programmed a melody to all necessary zones, move to step 5.
5. Hold down the "zone" button until you hear a short tone sound (approx 3 seconds) notifying the receiver is out of melody programming mode.

Volume, Mute, Off:

The volume button on the side of the receiver controls the four different volume levels, mutes & turns off the receiver. Pushing the volume button controls these functions.

- When all four zone LED lights are red, this indicates maximum volume.
- Three zone LED lights indicate the third volume level.
- Two zone LED lights indicate the second volume level.
- One zone LED light indicates the minimum volume level.
- No zone LED lights & a red power indicator light means the receiver is muted.
- No LED lights (no zone LED or power indicator) means the unit is off. Pushing volume again turns it back on to max volume.

Low Battery Indicator:

When the battery in the ERA-PBTX is low & needs to be replaced, it will signal the receiver to double play the programmed melody on the receiver when triggered. For example, if you have programmed the "ding-dong" sound for the push button to play on the receiver, when the battery in the push button is low, the receiver will play "ding-dong...ding-dong" when triggered to notify you to change the battery.

Deleting the Memory of the ERA-RXPG:

- On the ERA-RXPG receiver, hold down the "mode" button (lower button in figure 2) until you hear a short tone sound & the red LED (inside the front lens cover) begins to blink. This denotes the unit is in programming mode. Release this button.
- Simultaneously hold both the "mode" & "volume" button for approximately 5 seconds until you hear a quick chime sound.
- This notifies that the memory of the ERA-RXPG is been erased.

Mounting the Transmitter:

- The PIR sensor (transmitter) may be mounted in a variety of locations such as; on the ceiling, directly above the door, or side mounted. The most common mounting location is above the door.
- For best results, mount the transmitter above the door frame slightly canted in towards the door. You may cant (tilt) the unit to ensure the monitored zone is covering the area you want it to cover.

Mounting the Transmitter (cont.):

- Try to avoid mounting the transmitter/sensor near a heat or a/c duct, or in direct sunlight to help avoid false triggers.
- Changing the height of the sensor will change the size of the monitored zone. See table 1 below.

Height	Width	Depth
8'	9.20'	0.60'
10'	11.5'	0.75'
13'	14.95'	0.98'
16'	18.40'	1.20'

Table 1

*Height of Sensor (in feet) Changes Width and Depth of Monitored Zone.

1. Use included screw to mount the metallic bracket. We recommend mounting the bracket so that the openings on each end of the bracket are facing up (shaped liked a "U").
2. Each side of the transmitter has a screw protruding. That screw slides into the u-shaped openings of the bracket.
3. Insert the unit into the bracket. Each screw on the sides of the sensor should rest on open ends of the u-shaped bracket.
4. Tighten the screws on the side of the case just enough to keep it in place (do not let it fall out).
5. Tilt sensor in bracket to create desired monitored zone and test.
6. Tighten the screws on each side of the case to secure it to the bracket.

TECHNICAL SUPPORT

If you encounter any difficulty in the operation of this product after reading the manual, please contact us. You can reach us by phone at 904-245-1184 from 8:00 AM to 5:00 PM Monday through Friday (Eastern Standard Time). We will be happy to answer your questions and help you in any way we can.

WARRANTY

Safeguard Supply warrants this product to be free of defects in material and workmanship for a period of one year from the date of purchase. This warranty does not cover damage resulting from accident, abuse, act of God or improper operation. If this product does become defective, simply return it to Safeguard Supply. Please include a note

LEGAL NOTICES

This device complies with Part 15 of the FCC Rules. Operation is subject to the following two conditions: (1) this device may not cause harmful interference, and (2) this device must accept any interference received, including interference that may cause undesired operation. Changes or modifications not expressly approved by the party responsible for compliance could void the user's authority to operate the equipment. This equipment has been tested and found to comply with the limits for a Class B digital device, pursuant to Part 15 of the FCC Rules. These limits are designed to provide reasonable protection against harmful interference in a residential installation. This equipment generates, uses, and can radiate radio frequency energy and, if not installed and used in accordance with the instructions, may cause harmful interference to radio communications. However, there is no guarantee that interference will not occur in a particular installation. If this equipment does cause harmful interference to radio or television reception, which can be determined by turning the equipment off and on, the user is encouraged to try to correct the interference by one or more of the following measures: Reorient or relocate the receiving antenna.



WARNING: Cancer and Reproductive Harm. Go to www.P65Warnings.ca.gov for more information.